

SECTION C2 SERIES IW3250 STORM WALL®

TABLE OF CONTENTS

MAIN COMPONENTS.....	3-C2
ACCESSORIES	4-C2
MID-SPAN ANCHORS	5-C2



Due to the diversity in state/provincial, local and federal laws and codes that govern the design and application of architectural products, it is the responsibility of the individual architect, owner and installer to assure that products selected for use on projects comply with all applicable building codes and laws. United States Aluminum exercises no control over the use or application of its products, glazing materials and operating hardware and assumes no responsibility therefor.

The rapidly changing technology within the architectural aluminum products industry demands that United States Aluminum reserve the right to revise, discontinue or change any product line, specification or electronic media without prior written notice.





















THE SOLID CHOICE

www.usalum.com

2 1/2" x 6 1/4" for 7/16" Glazing

2 1/2" x 7" for 1 3/16" Glazing

Description	Part No. Length Pcs./Box	Clear # 11	Bronze # 22	Paint # 71	Description	Part No. Length Pcs./Box	Clear # 11	Bronze # 22	Paint # 71
 Vertical	IW909 24' 2	\$569.00	\$605.00	\$635.00	 Vertical	IW905 24' 2	\$767.00	\$806.00	\$839.00
 Horizontal	CW923 24' 4	273.00	312.00	345.00	 Horizontal	CW925 24' 4	322.00	364.00	398.00
 Horizontal Filler	CW950 24' 4	72.00	87.00	99.00	 Horizontal Filler	CW950 24' 4	72.00	87.00	99.00
 Pressure Bar	CW933 24' 12	80.00 Mill finish			 Pressure Bar	CW933 24' 12	80.00 Mill finish		
 Perimeter Pressure Bar	CW957 24' 6	113.00	127.00	138.00	 Perimeter Pressure Bar	CW952 24' 6	129.00	145.00	158.00
 Face Cap	CW901 24' 12	50.00	61.00	69.00	 Face Cap	CW901 24' 12	50.00	61.00	69.00
 Corner Mullion	IW179 24' 1	1267.00	1321.00	1364.00	 Corner Mullion	IW960 24' 1	1440.00	1500.00	1549.00
 Corner Pressure Bar	CW997 24' 4	154.00 Mill finish			 Corner Pressure Bar	CW993 24' 4	181.00 Mill finish		
 (2) required per corner Corner Face Cap	CW968 24' 4	59.00	72.00	82.00	 (2) required per corner Corner Face Cap	CW969 24' 4	70.00	85.00	98.00

52 Stock White and # 54 Hartford Green same price as bronze anodized.















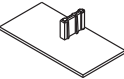
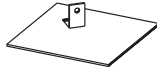
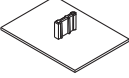
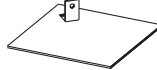

Black anodized same price as # 71 paint.

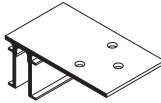
Paint prices shown are for the 20 standard colors shown on the United States Aluminum color cards.

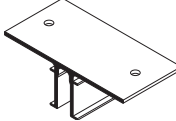
Not all items stocked at all locations, consult factory for availability. Minimum paint order per color is \$1500.00 list.

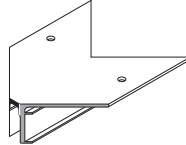
C2

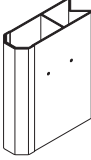
Accessories

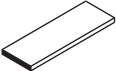
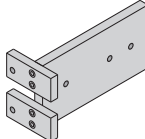
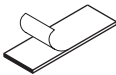
Description	Part No. Pcs./Box	Price	Description	Part No. Pcs./Box	Price
 Shear Block with Screws	AP695 20	\$64.00	 Pressure Bar Screw for 7/16" Glass	MS212 200	\$18.00
 End Dam for 7/16" Glazing	HD973 50	41.00	 Pressure Bar Screw for 1 3/16" Glass	MS222 200	22.00
 End Dam for 1 3/16" Glazing	HD975 50	51.00	 Corner Shear Block with Screws	AP696 8	95.00
 End Cap for 7/16" Glazing	CP925 50	58.00	 Corner End Cap for 7/16" Glass	CP965 10	118.00
 End Cap for 1 3/16" Glazing	CP900 50	48.00	 Corner End Cap for 1 3/16" Glass	CP901 10	118.00
 Temporary Glass Retainer	CW368 50	80.00	 Wall Jamb Anchor	AP691 6	65.00
 Exterior Gasket	NP432 500'	138.00	 Intermediate Mullion Anchor	AP689 12	139.00
 Interior Gasket	NP421 500'	305.00	 Corner Mullion Anchor	AP690 6	96.00
 Setting Block for 7/16" Glass	SB902 100	37.00	 Corner Mullion Splice Sleeve	SL979 5	56.00
 Edge Block for 7/16" Glass	WB902 50	23.00	 Mullion Splice Sleeve	SL909 12	128.00
 Setting Block for 1 3/16" Glass	SB901 100	66.00	 Drill Guide	DJ960 1	315.00
 Edge Block for 1 3/16" Glass	WB901 50	41.00			

Mid-Span Anchors (Deadload and Expansion)

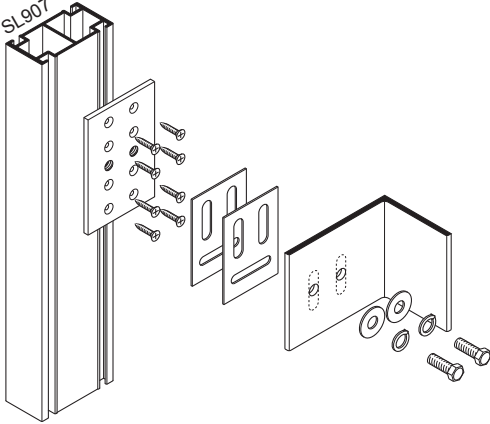
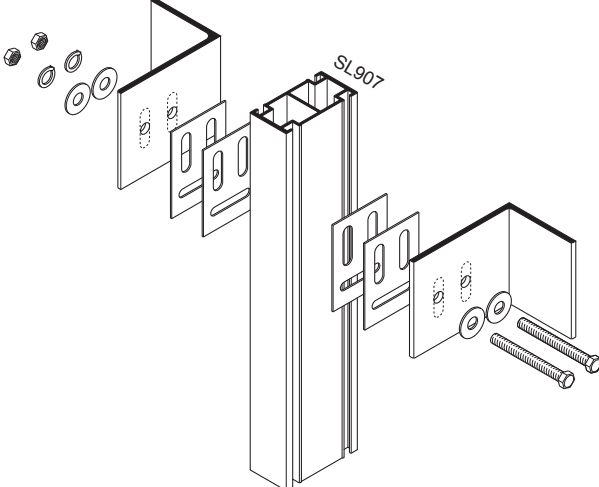
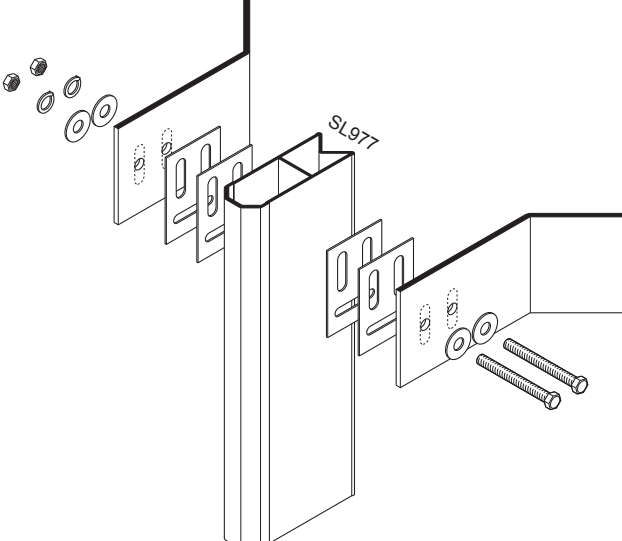
Description	Part No. Pcs./Box	Price
 <p>Anchor for Wall Jamb Includes: (1) TB681 Aluminum Tapping Bar (2) AP360 Nylatron Slip Pads (2) MF335 ½ -13 x 1½" GR-5 HH Bolts (2) MF257 Flat Washers (2) MF258 Lock Washers (8) ST277 #12 x1" FH Screws (1) SL907 Reinforcement Insert</p>	<p>AP681 6</p>	<p>\$280.00</p>
 <p>Anchor for Intermediate Vertical Includes: (4) AP360 Nylatron Slip Pads (2) MF351 ½ -13 x 4½" GR-5 HH Bolts (4) MF257 Flat Washers (2) MF258 Lock Washers (2) MF261 ½ -13 Hex Nut w/Nylon Lock (1) SL907 Reinforcement Insert</p>	<p>AP682 12</p>	<p>557.00</p>
 <p>Anchor for Corner Vertical Includes: (4) AP360 Nylatron Slip Pads (2) MF351 ½ -13 x 4½" GR-5 HH Bolts (4) MF257 Flat Washers (2) MF258 Lock Washers (2) MF261 ½ -13 Hex Nut w/Nylon Lock (1) SL977 Reinforcement Insert</p>	<p>AP683 6</p>	<p>285.00</p>

NOTE: Steel anchors shown are for reference only and are NOT included. (Designed per project)

C2

